



Akira Seiki USA Headquarters
Capitol Street Livermore
California USA

Akira Seiki Germany MMD WERKZEUGMASCHINEN GmbH
Industriestrasse 4 D-34308 Bad Emstal-sand

Akira Seiki Italy TECNOR MACCHINE S.P.A
Strada 3, Palazzo B4 20090 Assago

Akira Seiki Sweden LICHRON MACHINE TOOLS
Skovde Lichron.se

Akira Seiki Switzerland SUVEMA AG
Biberist suvema.ch

Akira Seiki Finland VOSSI MACHINETOOL
jarkko.vossi vossi.fi

Akira Seiki Taiwan AKIRA SEIKI Ltd
407 Taichung City Taiwan ROC

Akira Seiki Australia RELIANT MACHINE TOOLS
Melbourne Victoria

AKIRA SEIKI CNC Machine Tools

New Zealand Agent:
Revolution Precision Machinery
Tel: 03-960 0892
E-mail: sales@rpmcnc.co.nz
www.rpmcnc.co.nz

AKIRA VXP

AKIRA NEW LEVEL OF TECHNOLOGY

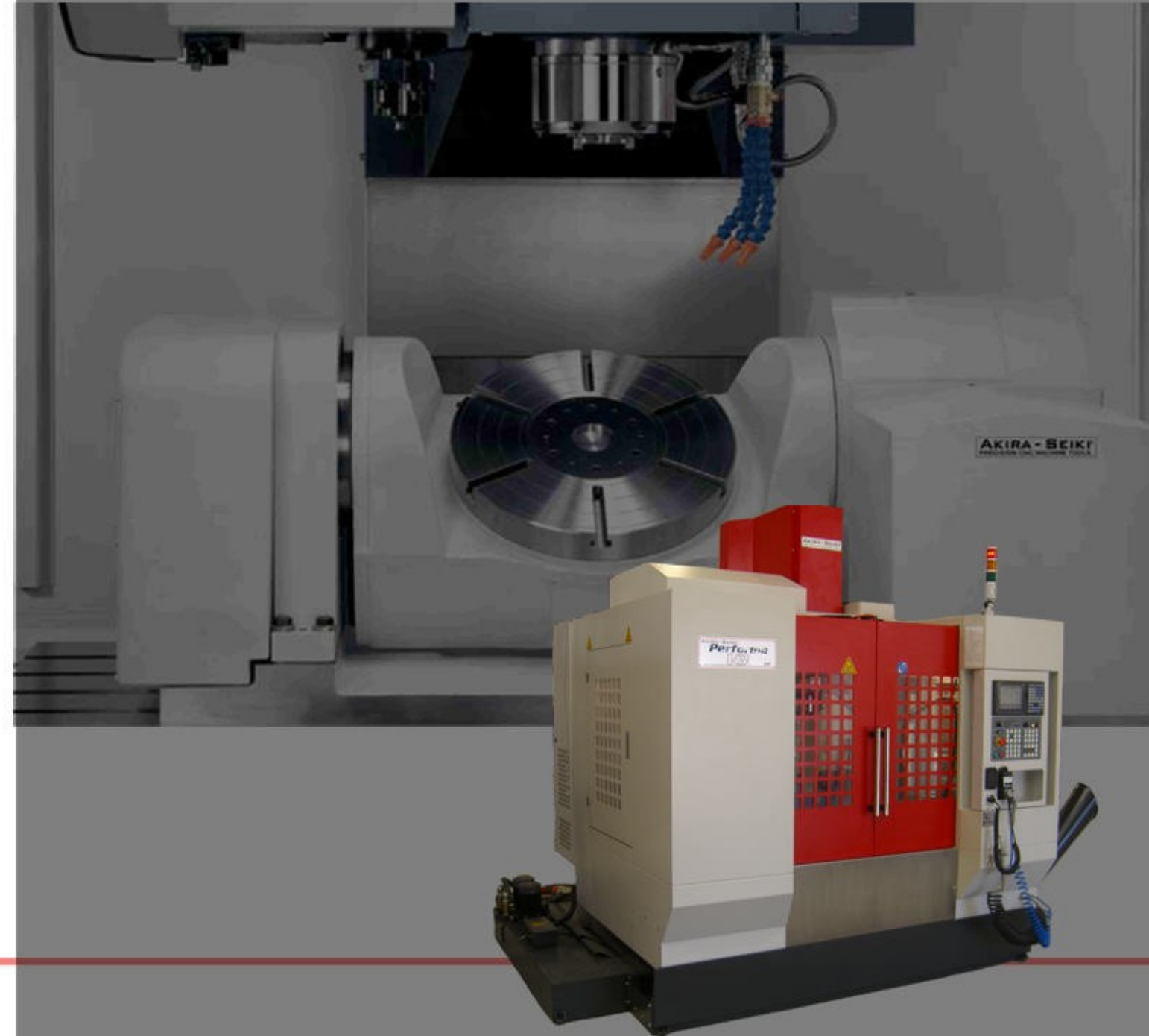

FAST-RIGID-DURABLE-ACCURATE
AKIRA VXP Series



Exceptional Performance Features

Akira M70A with 500 block pre-read

HSCM high speed contouring mode

44M / min rapid feed XY

12M / min cut feed

12,000 rpm balanced oil cooled spindle

30HP spindle motor

High table load capacity

28 Tool side mount fast ATC



Large Precision Ground Boxway Z Axis
Japan THK NR Ultra Rigid Guideways XY Axis
Heavy Duty Ultra Precision 4.5 Ball-Turn Ballscrews
Heavy Certified Meehanite Castings
High Assembly Quality

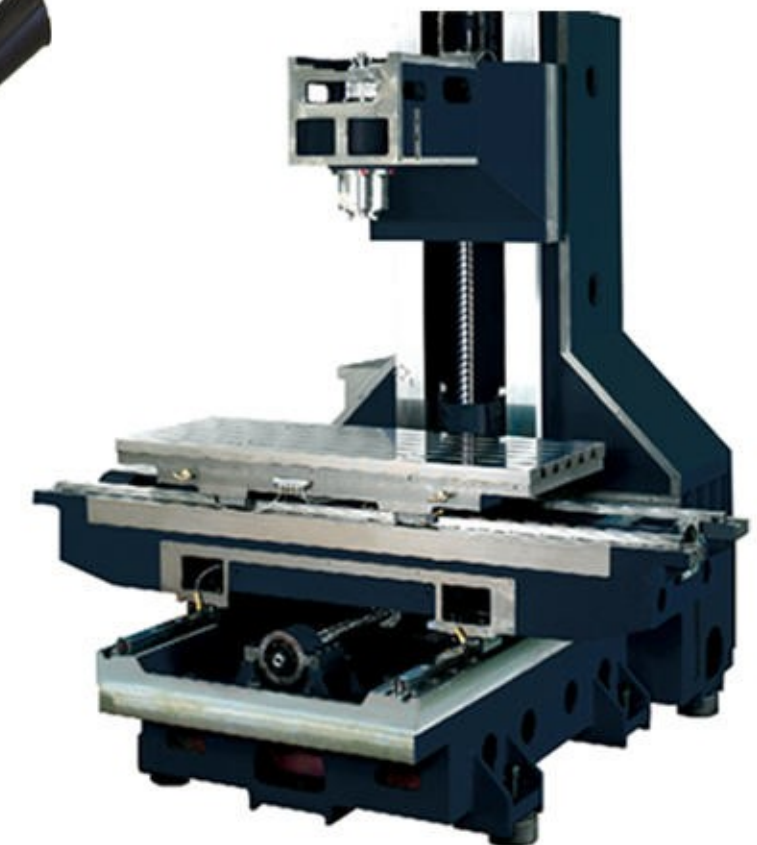

AKIRA VXP New Level of Technology

High Axial Loading Drive and Rapid Feed

- Least friction coefficient and preloading for clearance-free between moving surface, precise ball linear guide ways are most compatible for fast movement and high positioning & repeatability accuracy.
- To carry high cutting rapid and loading capability, the major feeding axes are in Japan THK most recommended NR type linear guide ways (THK patented).

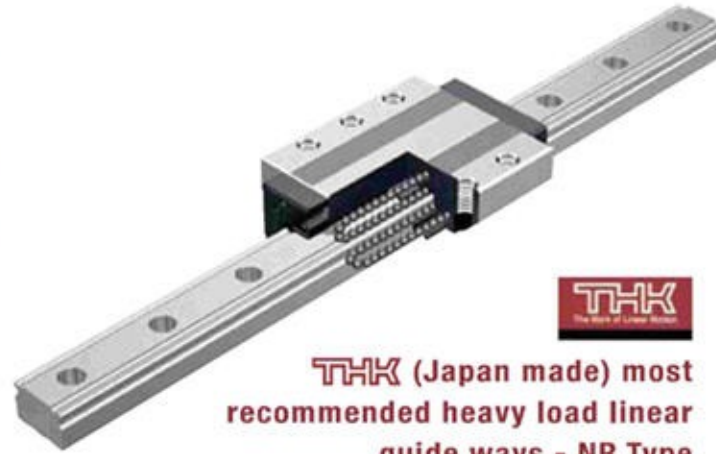

THK (Japan made) most recommended heavy load linear guide ways - NR Type

Ultra High Motion Rigidity

- NR type linear guide thicker flat-carrier block, low gravity center, 90 contact ball guides support 200% cutting load than others.
- Increased loading capacity on major load direction.
- Minimize ball diameter and increase ball numbers, raise up the effective contact rigidity to 30% than others.

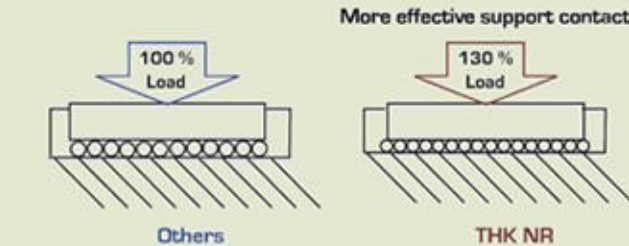
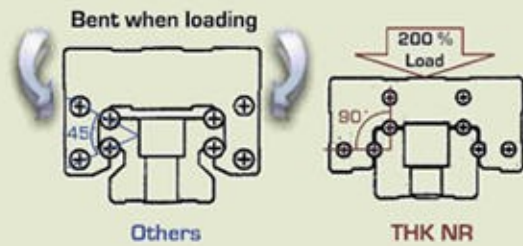

- Da 51% curvature achieve perfect ball rotary rigidity, less vibration when fast feed.

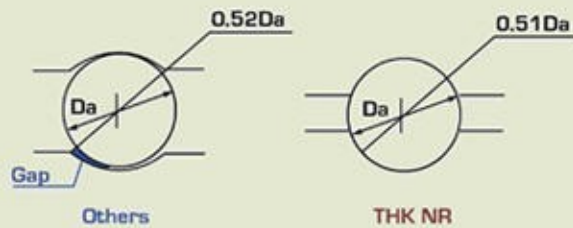

- Low gravity-center structure as most stable carrier while rapid cutting

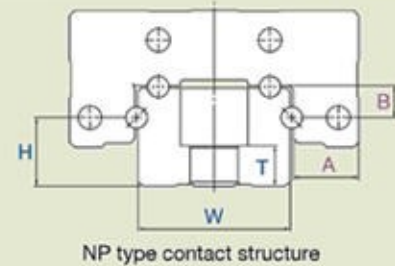

The height of "H" and "T" is short, it results in optimum small ratio between "H" and "W". Accordingly, the deformation of the NR rail under a lateral load is minimal, and the rigidity in the lateral directions is increased.

The height of "B" is short and the thickness "A" is large, the lateral extension of the LM block load of a reverse-radial or lateral is minimized. Results in increased rigidity.

Enforced Double-nutted Ballscrew



- Double-anchored ballscrew with ever extra broadened bearing nut than any others, enhance high speed cutting rigidity and accuracy while high cutting rapid feed.
- 100% laser track and ball bar collaboration test ensure the linear and ballscrew geometry accuracy.



Super Grade Precision Ballscrew

Tubeless ball-turn, free from noise

5-7dB lower than traditional series. The patented design of the return unit will reduce noises from impact of the ballnut's balls and its intensity.

Enforced transmission rigidity

Total 4-5 ball-turn channels increase the transmission loading capacity (standard for V / SV / HV-A / BV), 33% higher rigidity than traditional 3 ball-turn channel ballscrews.

Dm-N value up to 200,000

Enforced return structure achieving Dm-N value up to 200,000, which is 100% higher than traditional Dm-N value 100,000.

High acceleration and deceleration velocity

The pathway of the specialized return unit and ballnut's strengthened design diminish the impact experienced by the ball, it can sustain peak performance in more rigorous operating environments, such as high acceleration and deceleration.

Effective ballscrew thermal control

Ballcrew Hollow for Cooling (available option) allows the circular chilling pumped through. The very recommended feature for ballscrew reliable thermal control for frequent rapid operation in duration operation to assure high machining precision.

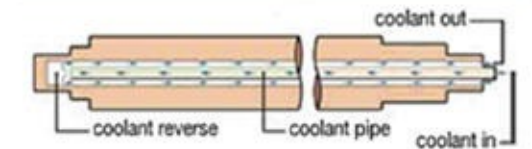
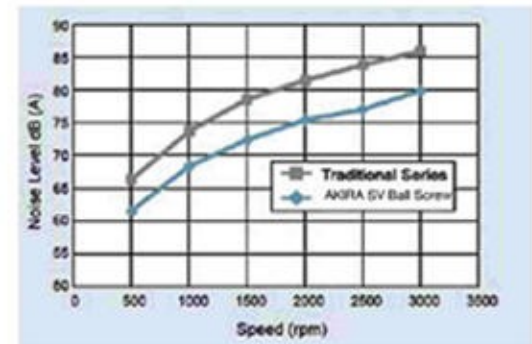
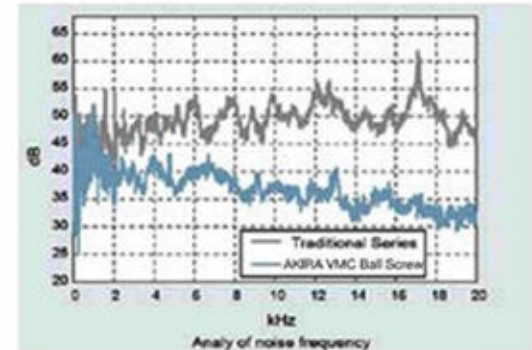

AKIRA VXP New Level of Technology

Operater Convenience Devices

Variable Coolant Solution



Coolant Through Spindle

- Combined with advance tooling technology for longer tooling longevity, the optional Coolant through Spindle(CTS) help to increase the higher cutting speed, chips removable for deep-hole drill and fine finishing of pocketing mill. 35-50 bar filtration pressure applied for efficient chip removable.

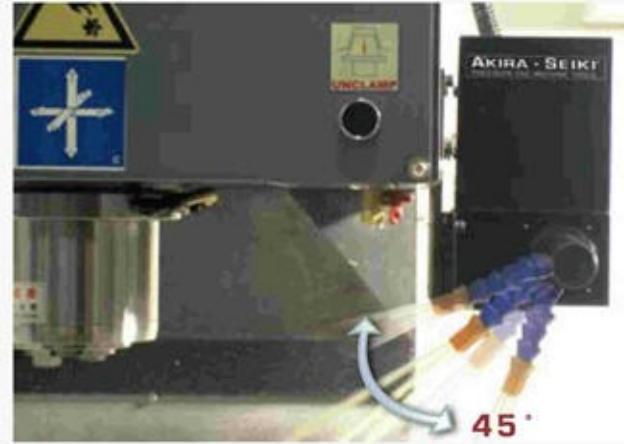

Programmable Coolant Nozzle

- The optional programmable coolant nozzle with easy setting by M codes supplies the coolant aiming directly on the working piece. A very convenient device to eliminate operator's manual adjustable inconvenience, coolant injection range from 0-45 degree.

4th & 5th NC Rotary Table Application

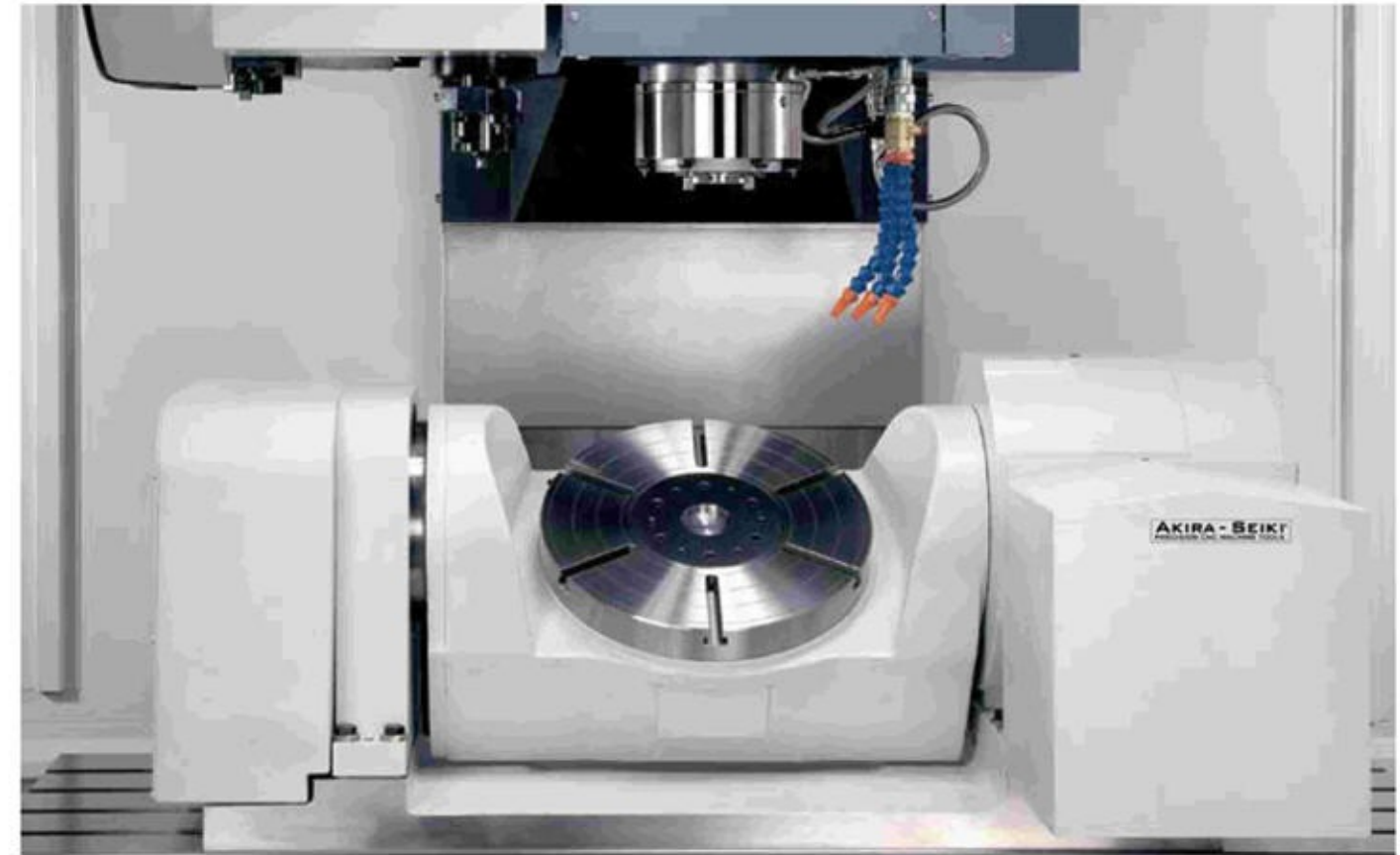

Rotary table application

- To increase the machining center package value, rotary table as full 4th axis is widely added in Akira Seiki offered proposal. The reduced set-up brings higher productivity and absolute parts accuracy.
- Up to 5 sided processing by tilting rotary table is available as another option.



Dia 350mm A/C axis on V5.5A

Tidy Operative Environment

Advance Environmental Coolant

MQL cutting solution

The advance semi-dry cutting way by Minimum Quantity Lubricant brings numerous benefit :

- Cost saved in least oil supply, free from conventional coolant waste.
- Extend tool life by instant lubricant and cool on tooling tips.
- High quality cutting surface.
- Environmental protection.



chilled and minimized lubricant

AKIRA VXP Series Specifications

		Performa V2 V2 XP	Performa V2.5 V2.5 XP	Performa V3 V3 XP	Performa V4 V4 XP	Performa V5 V5 XP	Performa V4.5 V4.5 XP	Performa V5.5 V5.5 XP	Performa V6 V6 XP	Performa V8 V8 XP
CONTROL SYSTEM		Akira Mi645(Fanuc code compatible)								
TRAVEL										
X Axis Travel	mm / inch	550 / 21.7	760 / 29.9	815 / 32.1	1050 / 41.3	1300 / 51.2	1150 / 45.3	1350 / 53.1	1630 / 64.2	2060 / 81.1
Y Axis Travel	mm / inch	435 / 17.1	435 / 17.1	540 / 21.3	540 / 21.3	540 / 21.3	640 / 25.2	640 / 25.2	850 / 33.5	850 / 33.5
Z Axis Travel	mm / inch	520 / 20.5	520 / 20.5	560 / 22.0	560 / 22.0	560 / 22.0	660 / 26.0	660 / 26.0	815 / 32.1	815 / 32.1
Spindle Nose To Table Surface	mm / inch	75-595 / 3-23.4	75-595 / 3-23.4	75-635 / 3-25	75-635 / 3-25	75-635 / 3-25	100-760 / 4-30	100-760 / 4-30	100-915 / 4-36	120-935 / 4.7-36.8
Spindle Center To Column Cover	mm / inch	450 / 17.7	450 / 17.7	550 / 21.7	550 / 21.7	550 / 21.7	670 / 26.4	670 / 26.4	860 / 33.9	860 / 33.9
TABLE										
Table Size (L*W)	mm / inch	700 x 400 / 28 x 16	910 x 400 / 36 x 16	950 x 480 / 37 x 19	1200 x 480 / 47 x 19	1450 x 480 / 57 x 19	1300 x 600 / 51 x 24	1500 x 600 / 59 x 24	1750 x 800 / 69 x 31	2150 x 800 / 85 x 31
T Slot (spec * pitch * number)	mm / inch	18 x 80 x 4 slot / 0.70 x 3.15 x 4 slot	18 x 80 x 4 slot / 0.70 x 3.15 x 4 slot	18 x 80 x 5 slot / 0.70 x 3.15 x 4 slot	18 x 80 x 5 slot / 0.70 x 3.15 x 5 slot	18 x 80 x 5 slot / 0.70 x 3.15 x 5 slot	18 x 100 x 5 slot / 0.70 x 3.15 x 5 slot	18 x 100 x 5 slot / 0.70 x 3.15 x 5 slot	18 x 125 x 6 slot / 0.70 x 4.9 x 6.5 slot	18 x 125 x 6 slot / 0.70 x 4.9 x 6.5 slot
Max. Loading	kgs / lbs	800 / 1764	1000 / 2205	1200 / 2646	1300 / 2867	1400 / 3087	2000 / 4410	2300 / 5072	3000 / 6615	4000 / 8820
Standard Loading	kgs / lbs	600 / 1323	800 / 1764	900 / 1985	980 / 2161	1080 / 2381	1300 / 2866.5	1500 / 3308	2300 / 5072	2700 / 5954
SPINDLE										
Max.Spindle Motor Power	HP	20 22+	20 22+	25 30+	25 30+	25 30+	25 30+	25 30+	25 30+	25 30+
Spindle Speed	rpm	9000 12000	9000 12000	9000 12000	9000 12000	9000 12000	9000 12000	9000 12000	9000 12000	9000 12000
Spindle Taper	ISO40	BT40 / CAT40	BT40 / CAT40	BT40 / CAT40	BT40 / CAT40	BT40 / CAT40	BT40 / CAT40	BT40 / CAT40	BT40 / CAT40	BT40 / CAT40
FEED										
Rapid Feed X/Y/Z	M/min ipm	40 / 40 / 30 1574 / 1574 / 1181 44 / 44 / 36 1732 / 1732 / 1417	40 / 40 / 30 1574 / 1574 / 1181 44 / 44 / 36 1732 / 1732 / 1417	40 / 40 / 25 1574 / 1574 / 984 44 / 44 / 25 1732 / 1732 / 1417	40 / 40 / 25 1574 / 1574 / 984 44 / 44 / 25 1732 / 1732 / 1417	40 / 40 / 25 1574 / 1574 / 984 44 / 44 / 25 1732 / 1732 / 1417	30 / 30 / 25 1181 / 1181 / 984 33 / 33 / 25 1299 / 1299 / 984	30 / 30 / 25 1181 / 1181 / 984 33 / 33 / 25 1299 / 1299 / 984	30 / 30 / 25 1181 / 1181 / 984 33 / 33 / 25 1299 / 1299 / 984	30 / 30 / 25 1181 / 1181 / 984 33 / 33 / 25 1299 / 1299 / 984
Cutting Feed Rate	M/min ipm	18 / 18 / 18 709 / 709 / 709 24 / 24 / 24 945 / 945 / 945	18 / 18 / 18 709 / 709 / 709 24 / 24 / 24 945 / 945 / 945	10 / 10 / 10 394 / 394 / 394 12 / 12 / 10 472 / 472 / 945	10 / 10 / 10 394 / 394 / 394 12 / 12 / 10 472 / 472 / 945	10 / 10 / 10 394 / 394 / 394 12 / 12 / 10 472 / 472 / 945	10 / 10 / 10 394 / 394 / 394 12 / 12 / 10 472 / 472 / 945	10 / 10 / 10 394 / 394 / 394 12 / 12 / 10 472 / 472 / 945	10 / 10 / 10 394 / 394 / 394 12 / 12 / 10 472 / 472 / 945	10 / 10 / 10 394 / 394 / 394 12 / 12 / 10 472 / 472 / 945
ACCURACY										
Positioning	mm / inch	±0.004 / ±0.00015	±0.004 / ±0.00015	±0.004 / ±0.00015	±0.004 / ±0.00015	±0.004 / ±0.00015	±0.004 / ±0.00015	±0.004 / ±0.00015	±0.004 / ±0.00015	±0.004 / ±0.00015
Repeatability	mm / inch	±0.002 / ±0.00008	±0.002 / ±0.00008	±0.002 / ±0.00008	±0.002 / ±0.00008	±0.002 / ±0.00008	±0.002 / ±0.00008	±0.002 / ±0.00008	±0.002 / ±0.00008	±0.002 / ±0.00008
ATC										
Tool "C" model - carousel ATC		C-20T	C-20T	C-24T	C-24T	C-24T	C-24T	C-24T	C-24T	C-24T
Storage "A" model - arm ATC		A-28T	A-28T	A-28T	A-28T	A-28T	A-28T	A-28T	A-28T	A-28T
Max. Tool Diameter	mm / inch	100 / 3.9 65 / 2.6	100 / 3.9 65 / 2.6	95 / 3.7 65 / 2.6	95 / 3.7 65 / 2.6	95 / 3.7 65 / 2.6	95 / 3.7 65 / 2.6	95 / 3.7 65 / 2.6	95 / 3.7 65 / 2.6	95 / 3.7 65 / 2.6
Max. Tool Diameter (without neighbor tool)	mm / inch	130 / 5.1 204 / 8.0	130 / 5.1 204 / 8.0	125 / 4.9 204 / 8.0	125 / 4.9 204 / 8.0	125 / 4.9 204 / 8.0	125 / 4.9 204 / 8.0	125 / 4.9 204 / 8.0	125 / 4.9 204 / 8.0	125 / 4.9 204 / 8.0
Max. Tool Length (mm)	mm / inch	350 / 13.8 300 / 11.8	350 / 13.8 300 / 11.8	350 / 13.8 300 / 11.8	350 / 13.8 300 / 11.8	350 / 13.8 300 / 11.8	350 / 13.8 300 / 11.8	350 / 13.8 300 / 11.8	350 / 13.8 300 / 11.8	350 / 13.8 300 / 11.8
Max. Tool Weight	kgs / lbs	8 / 0.3	8 / 0.3	8 / 0.3	8 / 0.3	8 / 0.3	8 / 0.3	8 / 0.3	8 / 0.3	8 / 0.3
Tool to Tool Time (60hz) for "A" model	sec.	3.8	3.8	3.8	3.8	3.8	3.8	3.8	3.8	3.8
GENERAL										
Tank Capacity	liter / gal	150 / 40	150 / 40	200 / 53	200 / 53	200 / 53	250 / 66	250 / 66	500 / 132	500 / 132
Chip Disposal		Drawer Chip Screw	Drawer Chip Screw	Drawer Chip Screw	Drawer Chip Screw	Drawer Chip Screw	Drawer Chip Screw	Drawer Chip Screw	Drawer Chip Screw	Drawer Chip Screw
Air Pressure Requirement	kgs / lbs (per cm ²)	6 / 13	6 / 13	7 / 15	7 / 15	7 / 15	7 / 15	7 / 15	7 / 15	7 / 15
Power Requirement	KVA	22	22	25	25	25	30	30	35	35
Floor Space (W*L)	mm / inch	1900 X 2200 / 75 X 87 2396 X 2200 / 94 X 87	2200 X 2200 / 87 X 87 2696 X 2200 / 106 X 87	2900 X 2280 / 114 X 90 3266 X 2280 / 129 X 90	3300 X 2280 / 130 X 90 3666 X 2280 / 144 X 90	3800 X 2280 / 150 X 90 4166 X 2280 / 164 X 90	3400 X 2495 / 134 X 98 3866 X 2495 / 152 X 98	3800 X 2495 / 150 X 98 4266 X 2495 / 168 X 98	4300 X 3580 / 169 X 141 4820 X 3580 / 190 X 141	5300 X 3580 / 209 X 141 5820 X 3580 / 229 X 141
Weight	kgs / lbs	3930 / 8646 4150 / 9130	4180 / 9196 4400 / 9680	5700 / 12540 6000 / 13200	6600 / 14520 6900 / 15180	7400 / 16280 7700 / 16940	7810 / 17182 8110 / 17842	8110 / 17842 8410 / 18502	12300 / 27060 12600 / 27720	14500 / 31900 14800 / 32560

Specifications dependant on country of use.

Listed performance data suitable for:

USA
Germany
Italy
Sweden
France
Australia
New Zealand

Japan specification please contact local agent

Specification may change due to improvements in product performance