

SAMSUNG Machine Tools

LCV 55 / 650 / 80

VERTICAL MACHINING CENTERS



SMEC

SAMSUNG MACHINE TOOLS

SMEC Co., Ltd.

667-1, Gasul-ri, Daesan-myeon, Changwon-si Gyeongsangnam-do, Korea 641-921

Tel +82 55 250 4832(4800) Fax +82 55 250 4901(4902)

<http://www.esmec.com>

SMEC

SAMSUNG MACHINE TOOLS



LCV 55
LCV 650
LCV 80

**SAMSUNG'S Advanced
Engineering and Machine Design**

**HEAVY DUTY, HIGH PRECISION AND COMPACT
VERTICAL MACHINING CENTERS**

Vertical machining center LCV 55

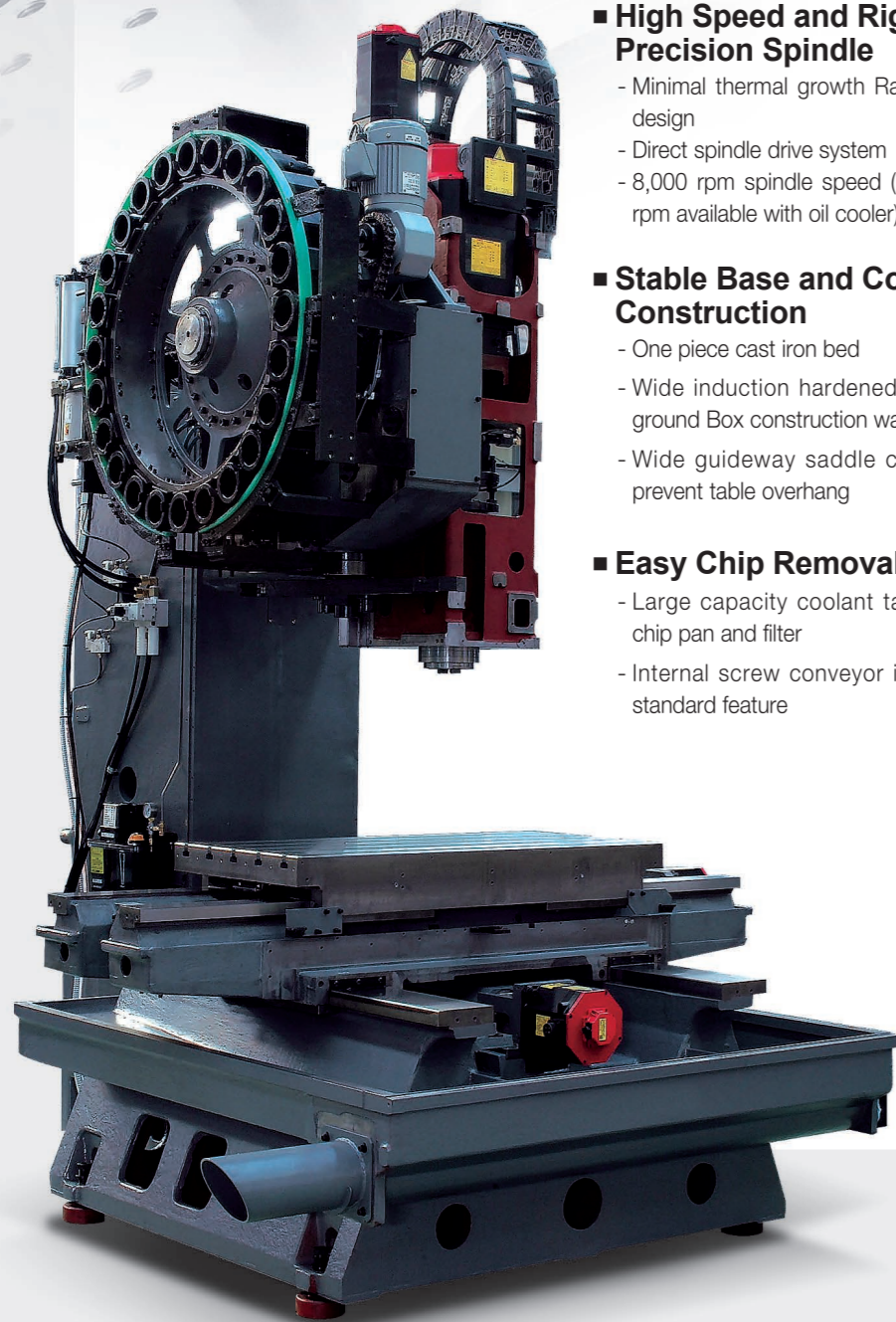

High Speed and Rigid Precision Spindle

- Minimal thermal growth Ram type spindle design
- Direct spindle drive system
- 8,000 rpm spindle speed (optional 12,000 rpm available with oil cooler)

Stable Base and Column Construction

- One piece cast iron bed
- Wide induction hardened and precision ground Box construction ways
- Wide guideway saddle construction to prevent table overhang

Easy Chip Removal Design

- Large capacity coolant tank (360L) with chip pan and filter
- Internal screw conveyor is equipped as standard feature

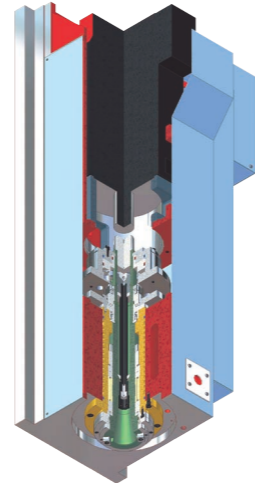

Spindle Speed

8,000 rpm

Spindle Motor (30min/cont.)

15/11 kW

Axes Travel (X/Y/Z)

1,150/550/520 mm

Vertical machining center LCV 650

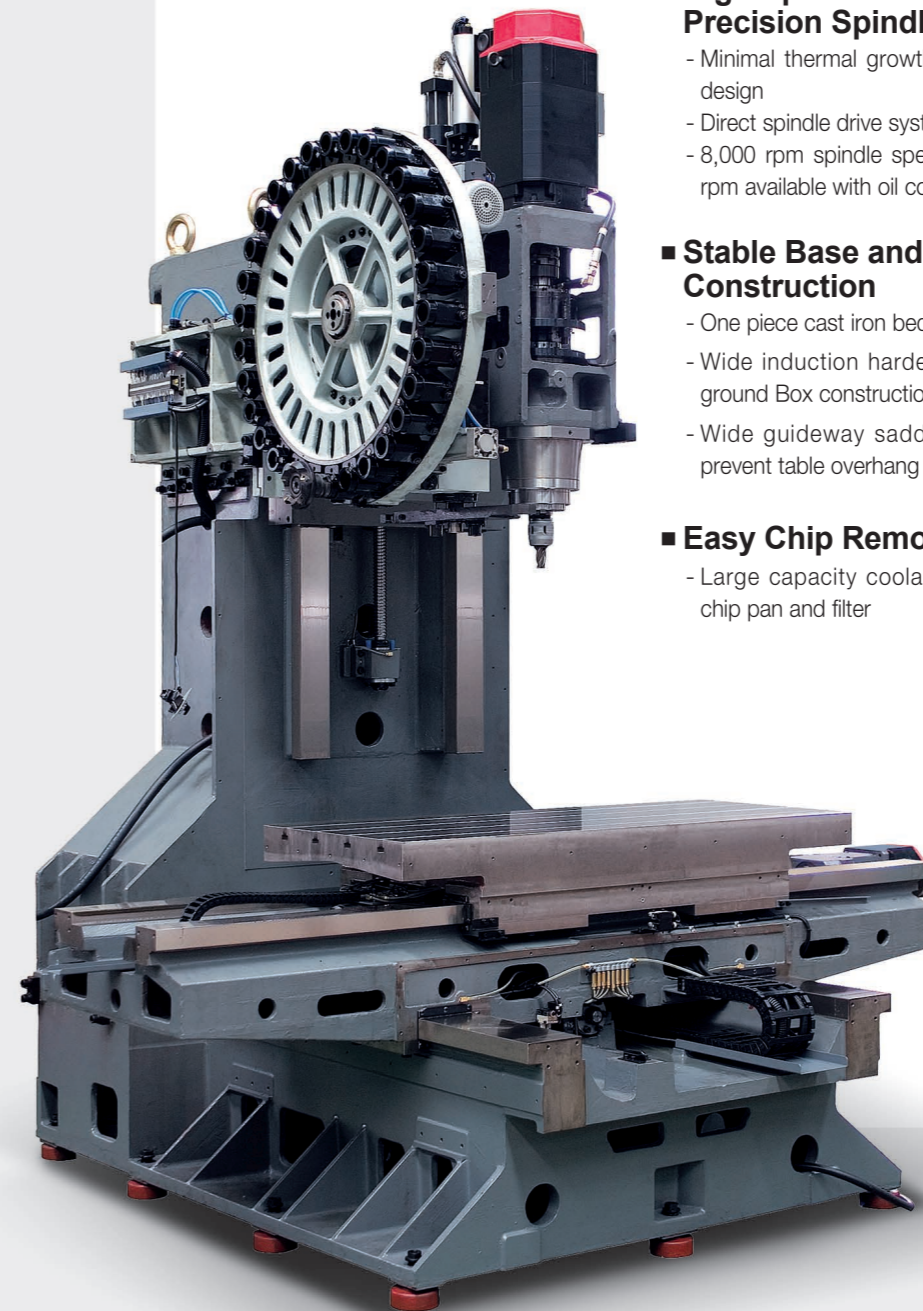

High Speed and Rigid Precision Spindle

- Minimal thermal growth Ram type spindle design
- Direct spindle drive system
- 8,000 rpm spindle speed (optional 12,000 rpm available with oil cooler)

Stable Base and Column Construction

- One piece cast iron bed
- Wide induction hardened and precision ground Box construction ways
- Wide guideway saddle construction to prevent table overhang

Easy Chip Removal Design

- Large capacity coolant tank (420L) with chip pan and filter

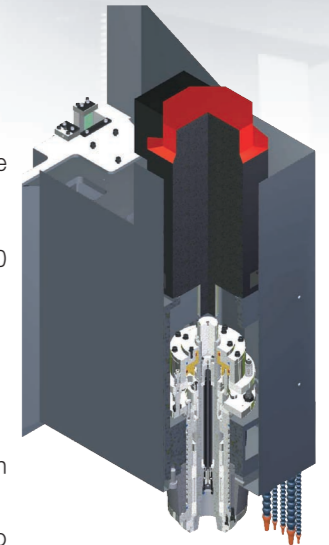

Spindle Speed

8,000 rpm

Spindle Motor (30min/cont.)

15/11 kW

Axes Travel (X/Y/Z)

1,350/650/635 mm

Vertical machining center

LCV 80

New Vertical Machining Center, Designed for High Productivity and Heavy Duty Machining

- Largest machining range in its class
- Rigid integrated Box guide ways construction with Meehanite cast iron
- Long term accuracy and superior surface finishes
- Wide column and outstanding structured spindle head
- Wide guideway construction for saddle and table to prevent overhang
- Classical rigid construction combined with advanced technology

Spindle Speed

8,000 rpm

Spindle Motor (30min/cont.)

18.5/15 kW

Axes Travel (X/Y/Z)

1,820/825/650 mm

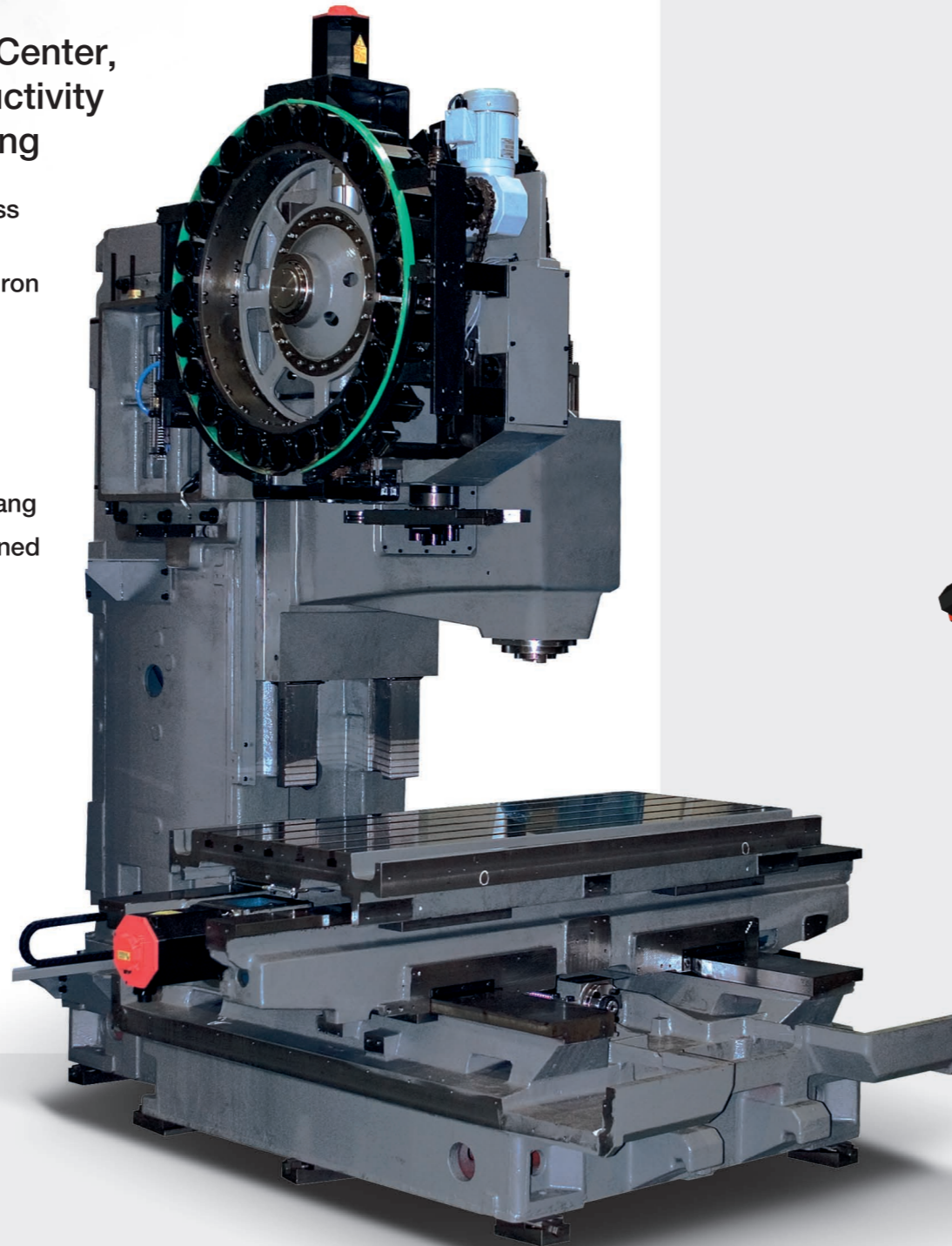

Rigid and Reliable Machine Construction

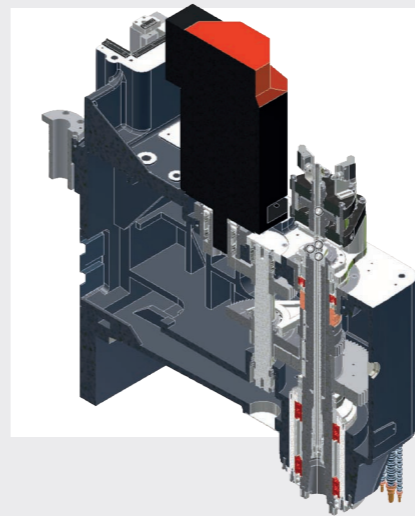

■ 2-Step Geared Headstock

High torque A.C. spindle motor with 2-step geared headstock delivers an impressive 62.5kgf.m of torque. Power is transferred through a ultra precision ground JIS '0' grade gear, promoting minimal gear noise and vibration free performance.

■ High speed and Rigid Spindle Structure

Adopting an oil cooling unit as a standard feature, LCV 80 Headstock structure ensures minimal heat displacement at any speed range, providing high precision and heavy-duty machining.

■ Large Size Ball Screws and Axis Drives



High precision double-nut ballscrews are centered between the guideways, ensuring outstanding positioning repeatability with virtually no thermal growth. All axes have large diameter 50mm(1.97") ballscrews connected directly to oversized AC servo motors.

■ Durable Bed, Saddle and Guideways Design

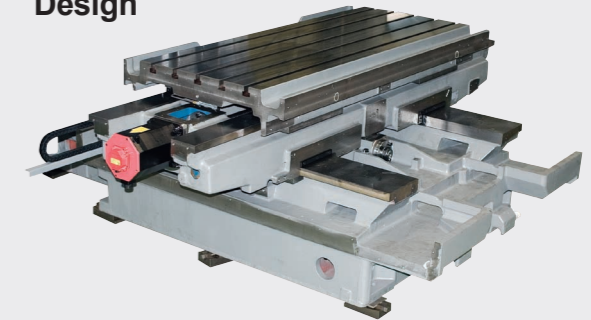

Wide Box guideways provide excellent support for the Saddle to prevent table overhang, and a rigid triangular rib body structure ensures minimal machine vibration and structural deformation even during heavy machining.

■ High Speed Tool Change

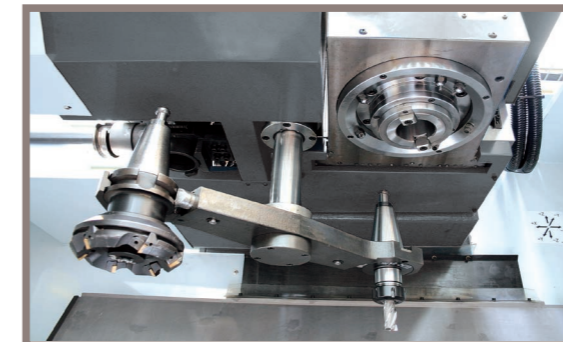

The twenty-four (24) tools Double Arm type ATC provides reliable and fast exchange of tools (tool-to-tool time: 2.5 seconds; chip-to-chip time: 5 seconds).

■ Wide Interior Working Space



With wide interior working space LCV 80 is capable of adopting various jigs and fixtures. Rotary table size up to 320mm can be installed on LCV 80.

Machine Dimensions

LCV55

Side View

Front View

Unit : mm

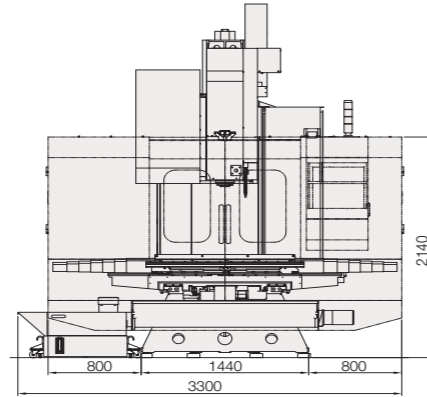
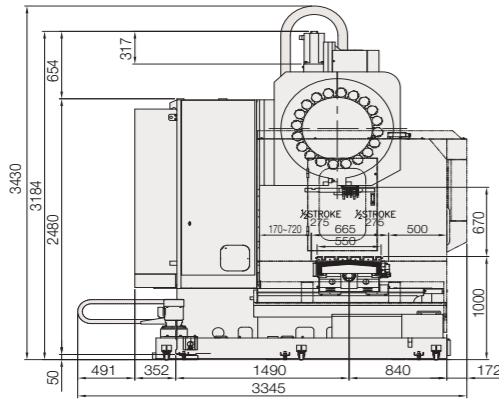

LCV650

Side View

Front View

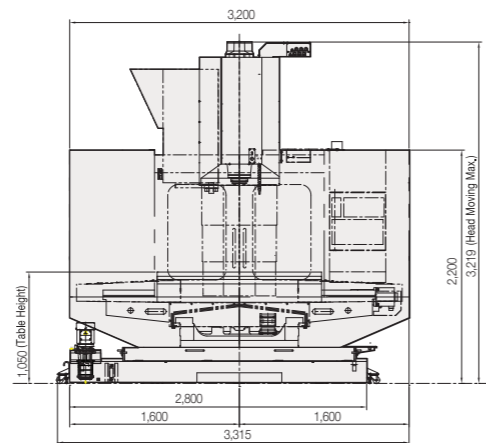
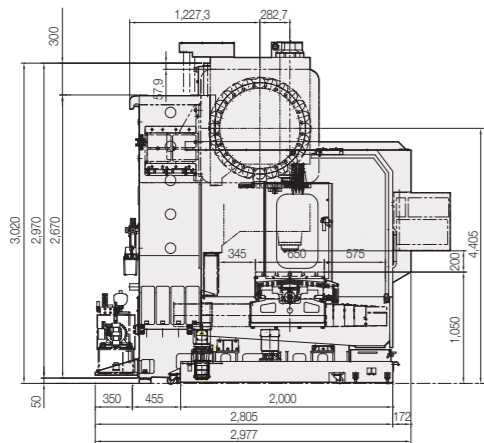

LCV80

Side View

Front View

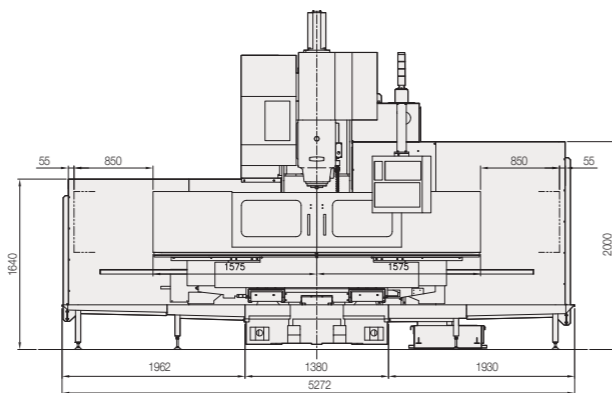
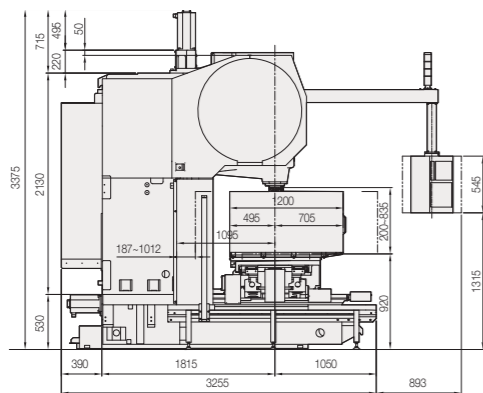

Machining Ranges and Spindle Torque Diagrams

LCV55

Max. Machining Range

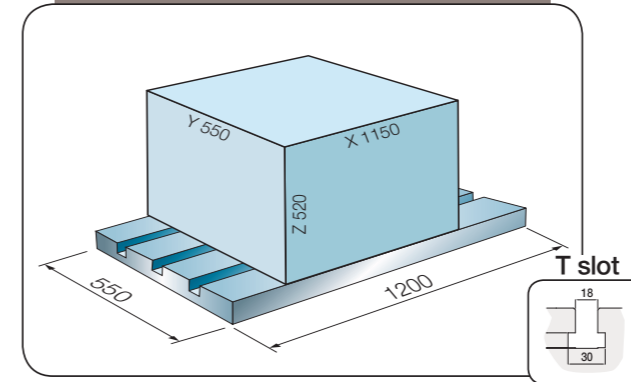

LCV650

Max. Machining Range

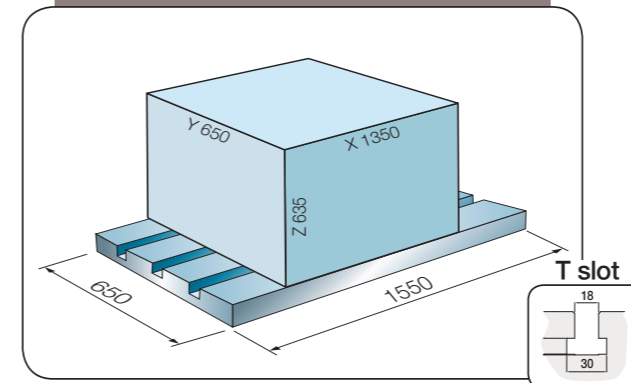

LCV80

Max. Machining Range

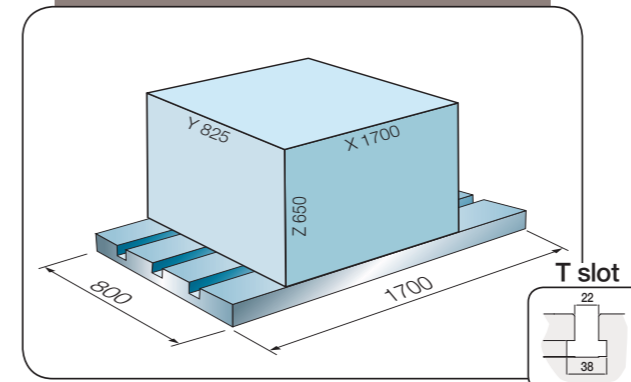

Spindle power and torque diagram

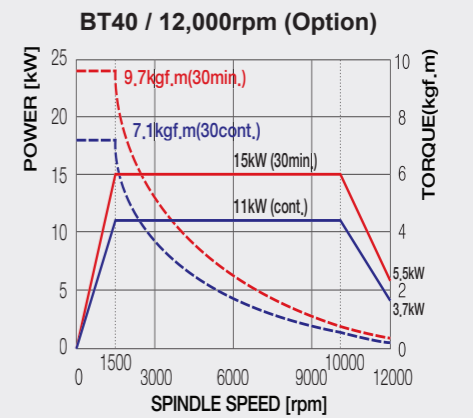
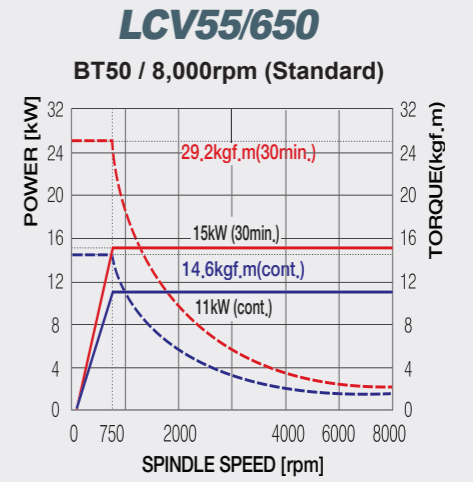

Spindle power and torque diagram

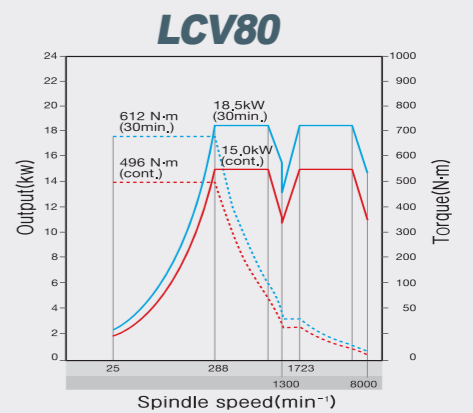

Major Specifications

DESCRIPTION		LCV55	LCV650	LCV80
Axis Travel[X/Y/Z]	mm	1150×550×520	1350×650×635	1820×825×650
Distance from Table top to Spindle nose	mm	150 ~ 670	200 ~ 835	200 ~ 850
Distance from Spindle Center to Column	mm	770	675	835
Distance Between T-slot / Width / No. of slot	mm	110 / 18 / 5 ea	125 / 18 / 5 ea	140 / 22 / 5 ea
Table Working Surface	mm	1,200×550	1,550×650	1,700×800
Allowable Load on Table	kgf	800	1000	2500
SPINDLE	Spindle Speed	rpm	8,000 (12,000)	
	Tool Shank Type		BT50 (BT40)	
	Bearing Inner Diameter (BT40)	mm	ø 85 (ø 65)	
	Motor[30min/cont.]	kW	15 / 11	
FEEDRATE	Rapid Traverse[X/Y/Z]	m/min	24×24×20	
	Cutting Feedrate	mm/min	1 ~ 10,000	
ATC	Storage Capacity		24	
	Changing Time [tool to tool]	sec	2.5	
	Max. Tool Weight (BT40)	kg	15 (8)	
	Max. Tool Length / Diameter (BT40)	mm	350 / ø 110 (ø 90)	
Required Floor Space	mm	3,725 × 2,850	3,315 × 2,977	5,272 × 4,150
Machine Weight	kg	6,500	11,000	15,000
Controller (Option)		Fanuc Oi-MD (Fanuc 31i-A)		

• Figures in inches are converted from metric measurements.
• Design and specifications subject to change without notice.

Standard Accessories

- Cutting Oil Unit
- Half Cover (LCV80)
- Fully Enclosed Splash Guard (LCV55, 65)
- Automatic Power Shutdown
- Work Light
- Leveling Blocks
- Standard Tool and Tool Box
- Coolant Unit
- Machine Manuals

Optional Accessories

- High Column (200mm increment : LCV55, 80)
- Lift-up Chip Conveyor
- Gun Coolant
- Air Blow
- Linear Scale
- Oil Skimmer
- Automatic Tool Length Measurement Unit
- Additional 1 Axis, 2 Axis Unit
- Oil Mist
- 3 Independent MPGs
- Data Server
- Through Spindle Coolant (LCV65, 80)

NC Specification / FANUC Oi-MD

Item		Specification
Controls	Control axis	3 Axis (X,Y,Z) Position (G00) / Linear interpolation (G01) 3 axis Circular interpolation (G02, G03) 2 axis 0.001mm (0.0001")
	Simultaneous control axis	
	Minimum input increment	
Spindle functions	Spindle speed command	S5 (5 characters) binary output
	Spindle speed override	50-120%
	Spindle orientation	Spindle orientation
Feed functions	Feed rate override (increasing by 10%)	0-200%
	Dwell	G04
	Reference position return	G27, G28, G29, G30
	Manual pulse generator	0.001/0.01/0.1mm(0.0001/0.001/0.01inch)
	Dry run	Dry run
Tool functions	Fast feed override	F0 (fine feed), 25/50/100%
	Tool no. command	T2 (2 Characters)
	Tool length correction	G43, G44
	Cutting correction type c	G41, G42
	Tool offset quantity	400EA
Programming functions	Absolute/increment programming	G90/G91
	Fixed cycle	G70~G72, G74~G76, G80, G83~G88
	Decimal number input	Input to decimal point value.
	Original preservation by radial programming	Radial programming by R instead with I,J,K value
	Sub program	Nexting to 4 steps
	Work coordinate system	G54-G59
	Local/machine coordinate system	G52/G53
	Max. order value	±99999,999mm(±9999.999inch)
M function	M3 (3 characters)	
Tape functions	Input code	ISO/EIA automatic recognition
	I/o interface	RS232C
	Machining program storing capacity	1,280
Other functions	Program storing ea.	400 Ea.
	Crt unit / mdi	8.4" color TFT LCD / soft input of MDI
	Graphic display	
	Synchronous tapping	Rigid tapping function
	Background edit	Machining program storing and editing of automatic drive.
	Backlash correction	Pitch error offset correction by each axis
	Pitch error correction storing	Backlash correction
	Safety function	Emergency stop / Over travel.
	Program test function	Machine lock (full axis/Z axis) / single block
	Handle function travel	Tape / Memory / MDI / Manual
	Mirror image	Back phase axis feed (Screen set and M function)
	Display drive time and machining quantity	Display drive time and part total quantity
	Self diagnostic function	Self diagnostic test
	Custom macro b	#100 ~ #199, #500 ~ #999
	Program re-start	Program Re-start
Display of pmc alarm message	Message display during PMC alarming	
Option	4 Axis function 3MPG	