

HIGH

Technology & Efficiency
Speed & Rigidity

Accuracy & Functions
Integration & Creditable



SAMSUNG MACHINE TOOLS

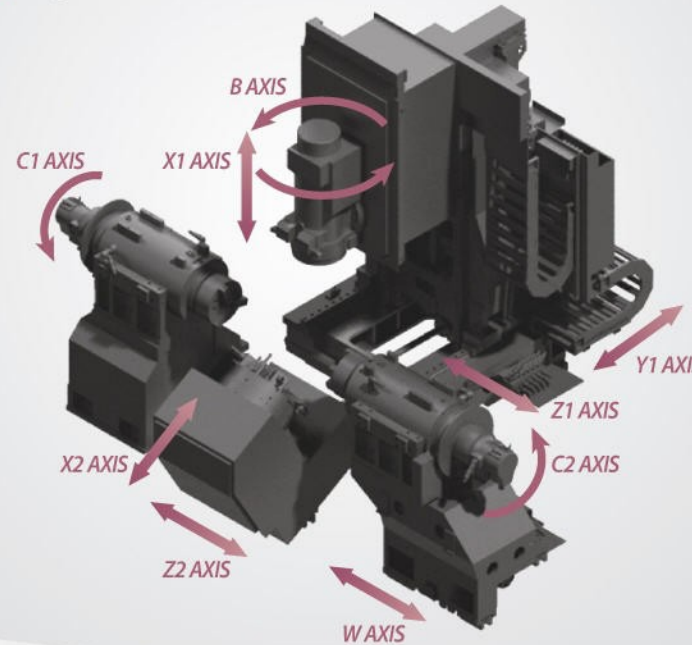

9-AXIS INTEGRATED MULTI-TASKING MACHINE

- 01 • Independent Orthogonal 3 Axis Milling Head Including B Axis
• Feedrate 50m/min, Rapid Drive System (Adoptation of High Speed Type B/screw and High Rigidity Roller Guide)
- 02 • Main/Sub Spindle
• High Accuracy C Axis Control by Adoption of Large Output Built-In Spindle
• Cooling System by High-capacity Dual Cooler
- 03 • Milling Spindle/ B Axis
• Large Output/High Rigidity Built-In Spindle(HSK63A Dual-Contact System)
• Guarantee High Reliability by Adoption of Air-Oil Lubrication System
• Strong Dual clamping in 3Pcs.Coupling+collet Wedge
• Strong/High Reliability B Axis(index 0.001) of Roller Drive Cam Type
- 04 • BMT55, 8Station High Rigidity Mill Turret, Standard 40 Tools (opt. 60/80 Tools) Chain Type Magazine.

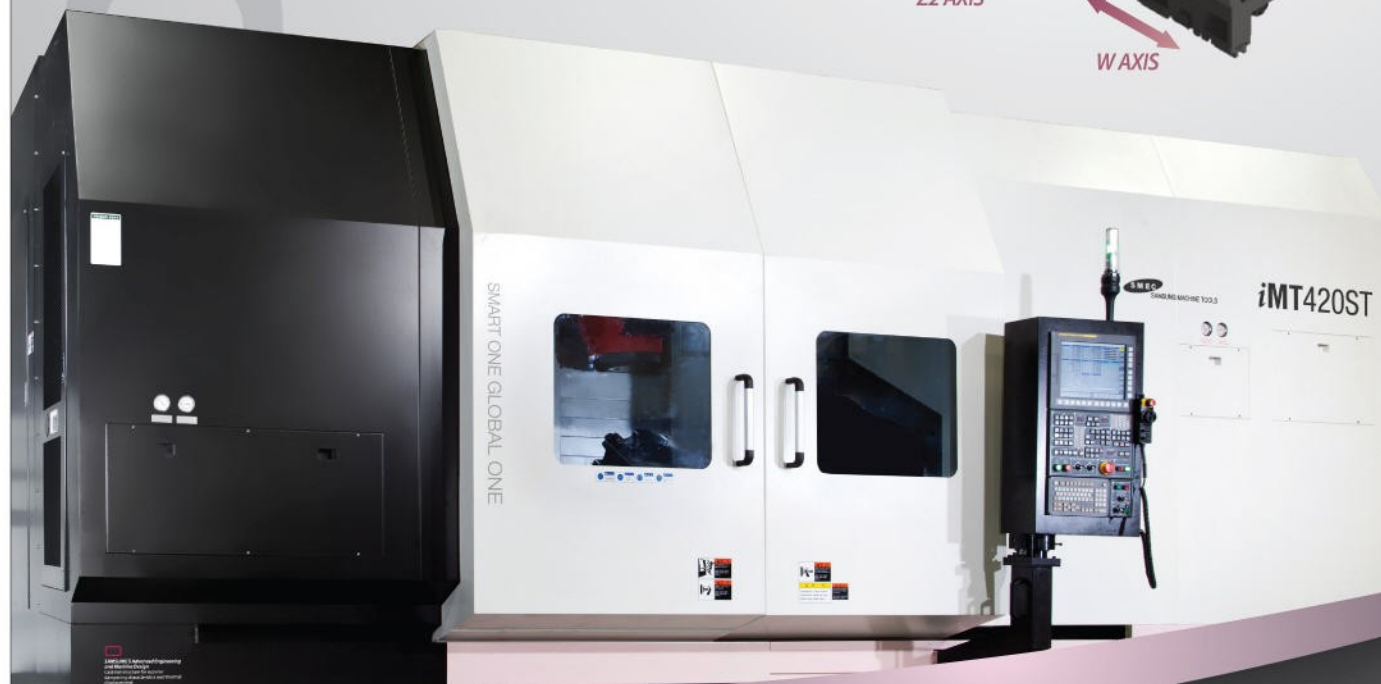

MULTI-TASKING MACHINE
iMT420ST

	ITEM	UNIT	SPECIFICATION
Capacity	Swing over bed	mm	∅670
	Max. turning diameter	mm	∅670 (∅420)
	Max. turning length (For tailstock)	mm	2018
Travels	X1 / Z1 axis	mm	850 / 2110
	B axis	deg	±120
	Y / W axis	mm	420 / 1950
	X2/ Z2 axis	mm	250 / 1900
1st Spindle /	Spindle speed	rpm	35-4000
	Chuck size (opt.)	inch	10" (12")
2nd Spindle	Spindle nose	ASA	A2-8
	Spindle through hole diameter	mm	∅78
	Min.spindle indexing angle (C axis)	deg	0,001
	Max. torque	Nm	600
Milling Spindle	Spindle speed	rpm	35-10000
	Turning tool size	mm	□25/∅40
Spindle	Max. torque	Nm	233
	Min.spindle indexing angle (B axis)	deg	0,001
	B axis index method		servo,M + CAM Index + 3 Pcs.coupling

	ITEM	UNIT	SPECIFICATION
ATC.	Tool shank		HSK 63A
	Magazine capacity (opt.)	ea	40 (60,80)
	Max. tool diameter/length/weight	mm	∅90 / 400 / 8
Turret(MC)	Tool changing time	sec	1,8(T-T)
	Turret shank		BMT55
	Number of tool stations	ea	8
	Square shank size	mm	□25 / ∅40
	Tool indexing time	sec	0,2
Feed rate	Rotary tool spindle speed	rpm	35-5000
	X1/X2 axis	m/min	50 / 50
	Z1/Z2 axis	m/min	50 / 50
	Y / W axis	m/min	30 / 50
	B axis	rpm	50
Machine size	C1/C2 axis	rpm	500
	Required floor space (LxWxH)	mm	6979x3063x3091
	Machine weight	kgf	18000
CNC System			FANUC 31i-B5

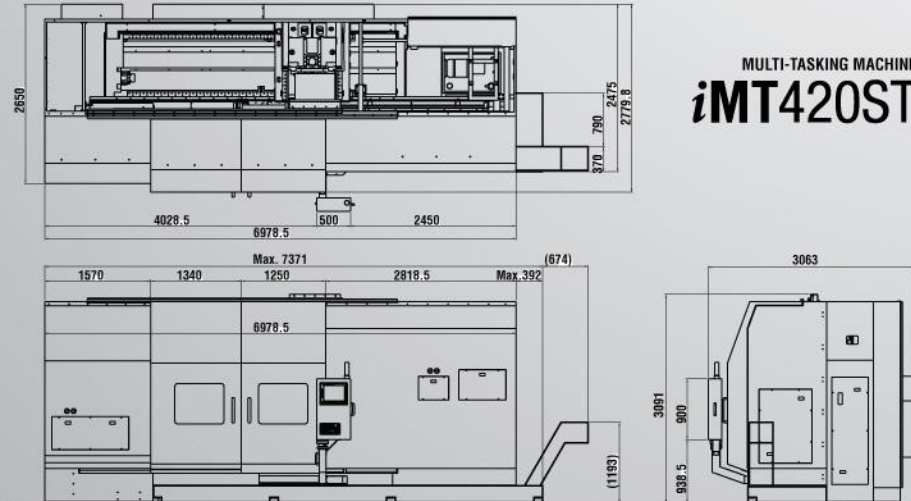

MULTI-TASKING MACHINE
iMT420ST

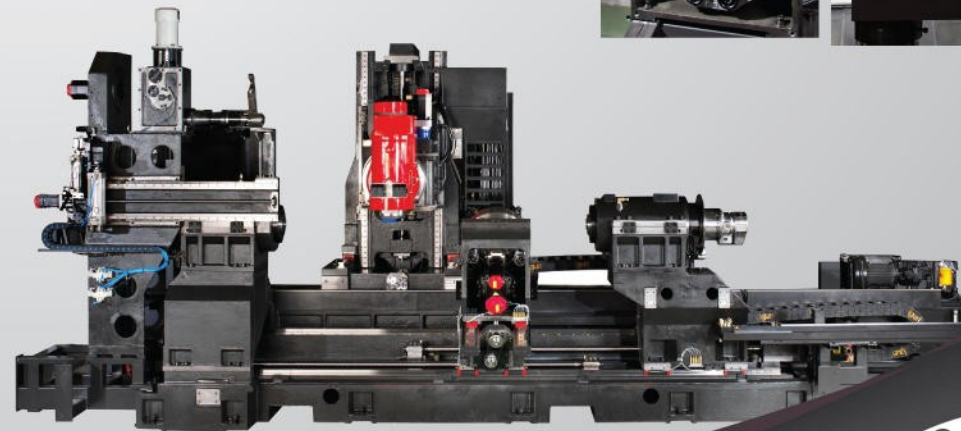

SMEC

www.esmec.com

SMEC _ SAMSUNG MACHINE TOOLS

SMEC Co., Ltd. 667-1, Gasul-ri, Daesan-myeon, Changwon-si Gyeongsangnam-do, Korea 641-921
Tel +82 55 250 4832(4800) Fax +82 55 250 4901(4902)